

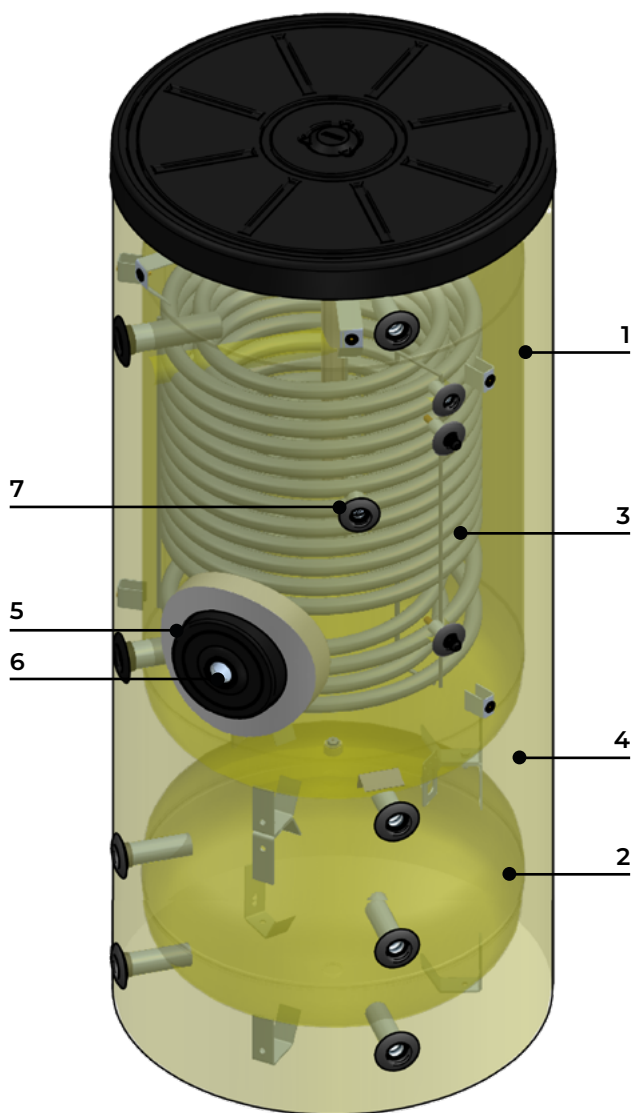

Combo Tank



Applications

The COMBO units integrate two functions into a single unit:

- Indirect production of hot water for sanitary use
- Thermal storage with hydraulic circuit separation, particularly suitable for heating/cooling applications with heat pumps.

Materials

Tank **1** and heat exchanger **3** for sanitary water management are made of carbon steel S 235 J, coated with "Blue Glass 4753" enamel using the flow-coating method at 850°C, certified by WRAS (BS6920-1). The technical water storage tank **2** is made of raw S 235 J steel. The insulation **4** is made of polyurethane foam (PU) with an adequate thickness for operation with hot or chilled water.

Range

The range consists of 3 units with domestic water content of 178, 251 and 360 liters and a corresponding technical water content of 44, 57 and 64 liters.

Standard Equipment

The section related to DHW (Domestic Hot Water) production is equipped with an inspection flange **5** Ø DN 180. In the same section, there is a 1½" fitting for the insertion of an auxiliary electric resistance **6** and the presence of two wells for temperature reading **7**.

The section related to technical water includes 4 fittings of ¾" for the 200-liter model and 1" for the 300-liter and 400-liter models.

Protection systems

The section responsible for the production of domestic hot water includes a magnesium anode for cathodic protection. It also features a ½" auxiliary connection for the optional installation of an electronic anode (not included).

Accessories

Electric kits are available to complement the heat exchanger for the production of domestic hot water.

COMBO TANK

Application Scheme

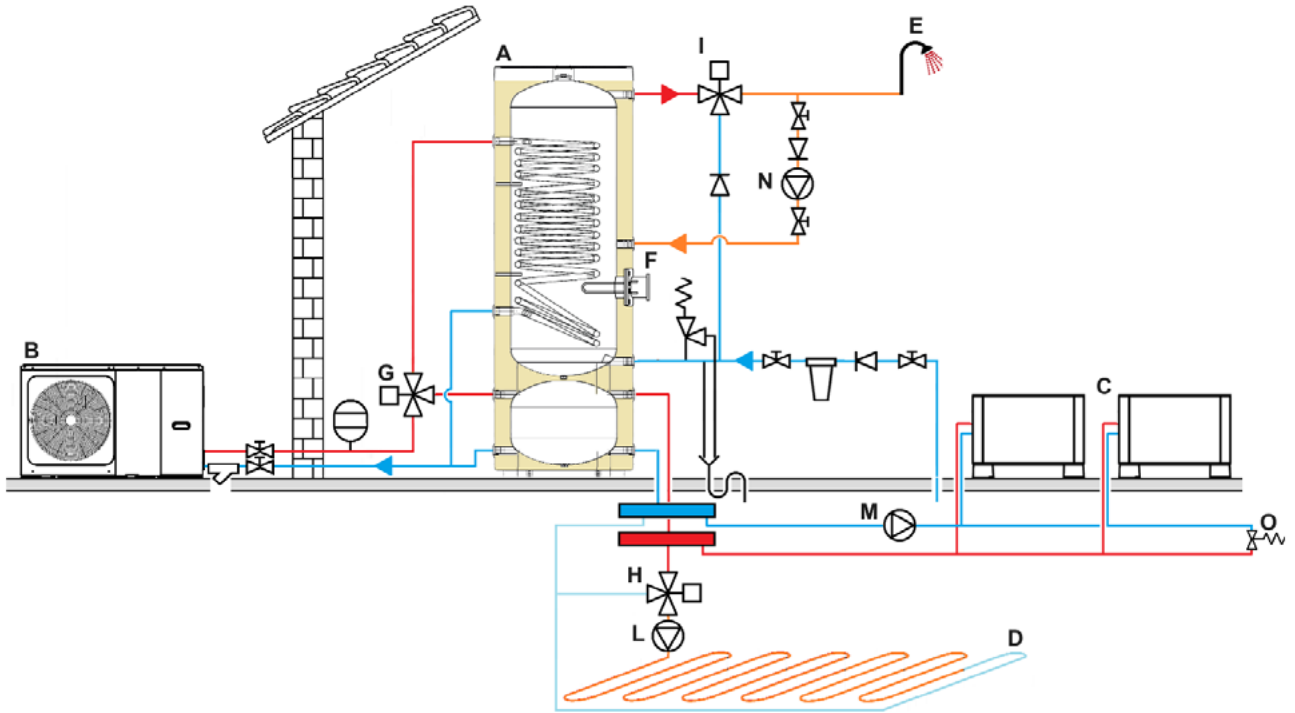

REF.	DESCRIPTION	REF.	DESCRIPTION
A	COMBO-TANK Unit	G	3-way diverting valve
B	Power generator - Heat pump	H	Three-way mixing valve
C	Direct air conditioning load	I	Thermostatic valve
D	Mixed air conditioning load	L	Circulator on mixed branch
E	Domestic hot water user	M	Circulator on direct branch
F	Electric integration generator	N	Circulator on the recirculation loop of the sanitary hot water system
O	Pressure Relief Valve		

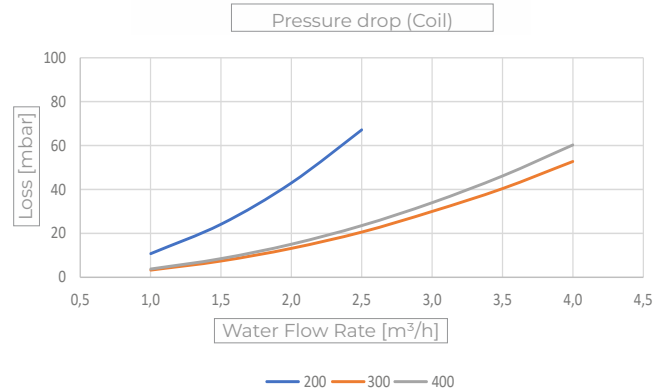
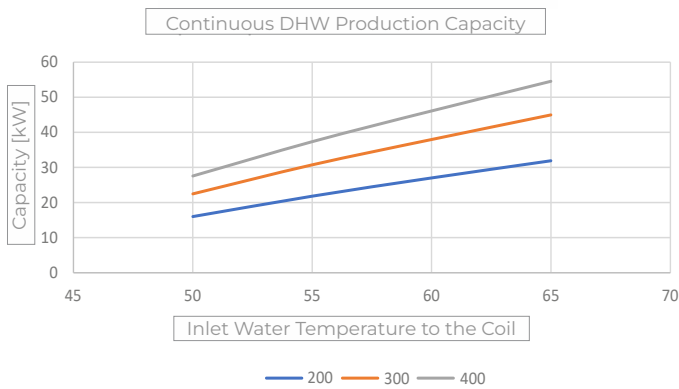



Combo Tank

SERIES ISSWC 200-300-400



ErP Energy Class



The Combo Tank is the perfect solution for optimizing space by combining two separate tanks in heat pump-powered systems. Offered in three sizes, it provides the flexibility to meet diverse needs, making it the ideal choice for efficiently managing both heating and domestic hot-water requirements in a single, compact unit.

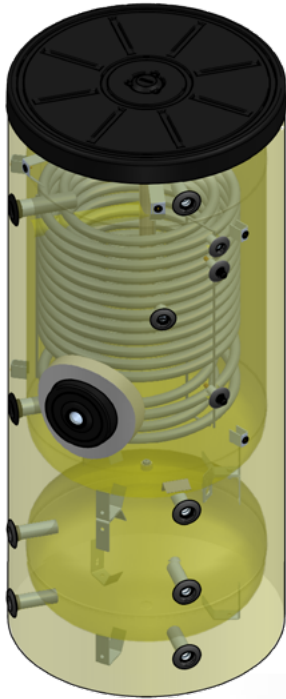

- DHW storage tank featuring a high-quality enameled coating, 'Blue Glass 4753,' certified WRAS (BS6920-1) and KTW-BWGL in compliance with UBA (German Environmental Agency) standards
- Buffer tank made of S 235 Jr carbon steel, engineered for optimal performance with water temperatures ranging from -5°C to 95°C
- External casing made of durable ABS RAL 9016
- Superior thermal insulation with eco-friendly rigid polyurethane foam (PU) with optimal thickness, designed for reliable operation with both hot and chilled water
- Flange for cleaning the tank or installing an electric heater
- Ideal for installation in buildings with underfloor heating systems



ACCESSORIES PP. 88

WARRANTY:

- 5 YEARS ON THE TANK
- 2 YEARS ON THE OTHER COMPONENTS

TECHNICAL DATA	ISSWC			
	Size	200	300	400
	Code	FU000102	FU000103	FU000104
DHW capacity	l	178	251	360
Heating capacity	l	44	56	63
Net weight (empty)	kg	83	120	165
Nominal power of the compatible heat pump	kW	6	10	14
Heat exchanger surface area	m ²	1,7	2,7	3,6
Reference water flow rate	m ³ /h	2	3	3
Continuous production of domestic hot water (DHW)*	kW	27	38	46
Continuous production of domestic hot water (DHW)*	l/h	665	936	1133
Pressure drop	mbar	43	30	34
Heat exchanger content	l	13	21	26.5
Insulation thickness	mm	50	50	50
ErP Heat Loss Watt	W/h	58	66	74
Erp Energy Class		B	B	B
Maximum operating pressure for sanitary storage	bar	6	6	6
Maximum temperature for sanitary storage	°C	95	95	95
Maximum operating pressure for the heat exchanger	bar	10	10	10
Maximum temperature for the heat exchanger	°C	105	105	105
Maximum operating pressure for the thermal buffer tank	bar	4	4	4
Maximum technical water temperature	°C	95	95	95
Minimum technical water temperature	°C	-5	-5	-5

*Coil Inlet Water Temperature: 60°C - Sanitary Water Production Between 10°C and 45°C

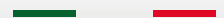

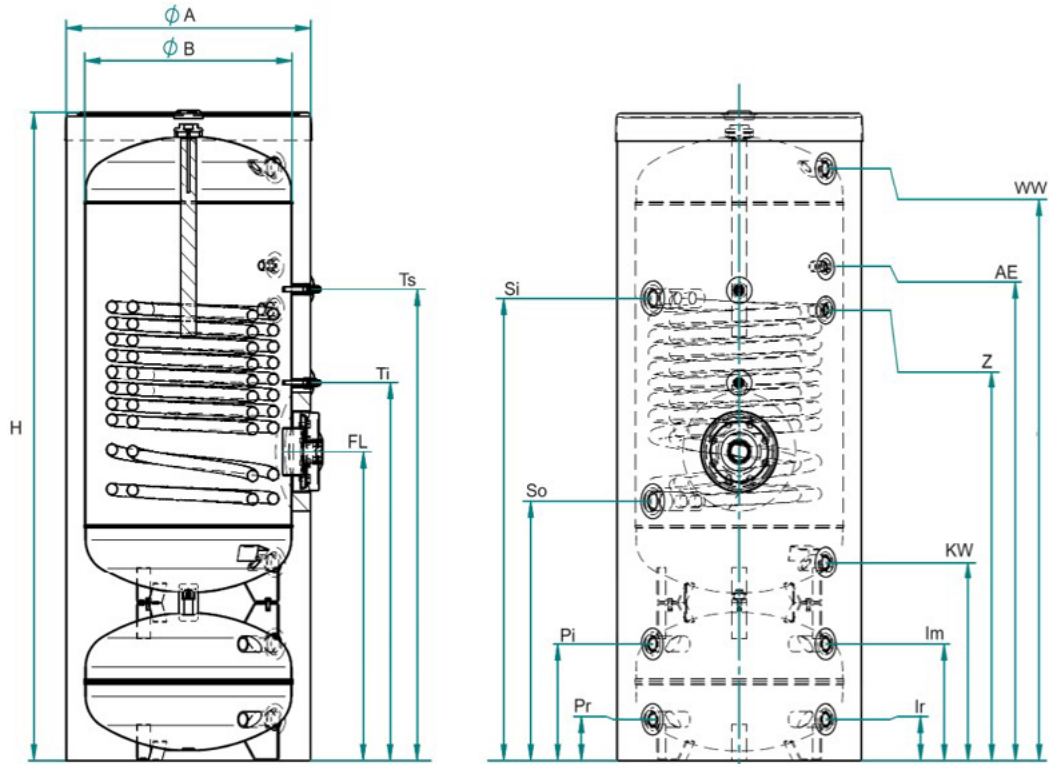

DIMENSIONS	U.M.	200	300	400	
Diameter with insulation	ØA	[mm]	544	651	751
Total height with insulation	H	mm	1732	1652	1776
Tipping diagonal	-	mm	1815	1830	1980
Flange	FL	mm	750	792	911
Lower dry-well	Ti	mm	952	852	951
Upper dry-well	Ts	mm	1402	1182	1371
Return to heat pump	Pr	mm	98	104	124
Inlet from heat pump	Pi	mm	350	304	350
Coil outlet	So	mm	664	667	766
Coil inlet	Si	mm	1480	1264	1427
Return from system	Ir	mm	98	104	124
Supply to system	Im	mm	350	304	350
Domestic hot water inlet	KW	mm	546	512	598
Recirculation	Z	mm	1302	1102	1251
Auxiliary connection for electronic anode	AE	mm	1502	1282	1451
Domestic hot water supply	WW	mm	1618	1512	1626
CONNECTIONS	REF	200	300	400	
Lower dry-well	Ti	Rp 1/2"	Rp 1/2"	Rp 1/2"	
Upper dry-well	Ts	Rp 1/2"	Rp 1/2"	Rp 1/2"	
Return to heat pump	Pr	G 3/4"	Rp 1"	Rp 1"	
Inlet from heat pump	Pi	G 3/4"	Rp 1"	Rp 1"	
Coil outlet	So	Rp 1"	Rp 1" 1/4	Rp 1" 1/4	
Coil inlet	Si	Rp 1"	Rp 1" 1/4	Rp 1" 1/4	
Return from system	Ir	G 3/4"	Rp 1"	Rp 1"	
Supply to system	Im	G 3/4"	Rp 1"	Rp 1"	
Domestic hot water inlet	KW	G 3/4"	Rp 1"	Rp 1"	
Recirculation	Z	Rp 3/4"	Rp 3/4"	Rp 3/4"	
Auxiliary connection for electronic anode	AE	Rp 1/2"	Rp 1/2"	Rp 1/2"	
Domestic hot water supply	WW	G 3/4"	Rp 1"	Rp 1"	